

# COMPANY PROFILE



**CIARA 4.0 FURNITURE MANUFACTURING FACTORY**

- LETTER OF INTRODUCTION 03
- COMPANY INFORMATION 04
- LEGAL PROFILE 05
- FACTORY SCALE 06
- COMPANY HISTORY & DEVELOPMENT JOURNEY 08
- VISION & MISSION 09
- COMPANY ORGANIZATIONAL CHART 10
- MACHINERY & EQUIPMENT 12
- INDUSTRY 4.0 AUTOMATED PRODUCTION LINES 20
- PRODUCTS 24
- HIGHLIGHTED PROJECTS 40
- WHY CHOOSE US 70

# CIARA

## LETTER OF INTRODUCTION

Vietnam Forestry and Agriculture Investment Development Co., Ltd (VINAFAI) was established in 2001 by the Vietnam Timber and Forest Products Association, specializing in the manufacturing and trading of natural wooden furniture.

In 2011, VINAFAI became the main investor in the “High-Tech Wood Processing Craft Village Industrial Cluster” project, covering 14 hectares in Tu Son, Bac Ninh.

Over the past 20+ years, VINAFAI has gradually affirmed its position in the market as a reputable manufacturer and supplier of furniture for high-end apartment projects, villas, resorts, and office spaces.

In 2021, VINAFAI signed a cooperation agreement with the Ministry of Science and Technology to implement the National Technology Innovation program for the project “Building an automated production line for joinery products from artificial boards.” This marked a transformation in the production line, shifting from natural wood furniture to engineered wood (wood-based panels) under the brand CIARA, inheriting expertise from professional experts, designers, and technical teams.

As the first company to apply Industry 4.0 technology in engineered wood furniture production, CIARA is equipped with modern machinery, a standard-compliant factory, and a professional workforce – ensuring fast and optimal responses to both domestic and international customer demands.

With the motto: “Customers are the key to CIARA’s existence and growth”, we are committed to working with dedication and delivering the most practical values to our clients.

With a spirit of cooperation and sustainable development, CIARA confidently meets the needs of our partners and customers through high-quality products, outstanding service, and competitive pricing.

**CIARA – Furniture For Your Dream**  
Sincerely thank you!

General Director



Nguyễn Đình Dũng



# ◆ COMPANY'S INFORMATION

**Company Name:** VIETNAM FORESTRY AGRICULTURE DEVELOPMENT INVESTMENT CO. LTD

**Abbreviated Name:** VINA FADI CO.,LTD

**Tax Code:** 0101189601

**Address:** High-tech Craft Village Industrial Cluster, Tam Son Ward, Bac Ninh Province, Vietnam.

**Phone:** 094.191.3568

**Website:** noithatciara.com

**Email:** quanly@ciara.com.vn

# ◆ LEGAL PROFILE

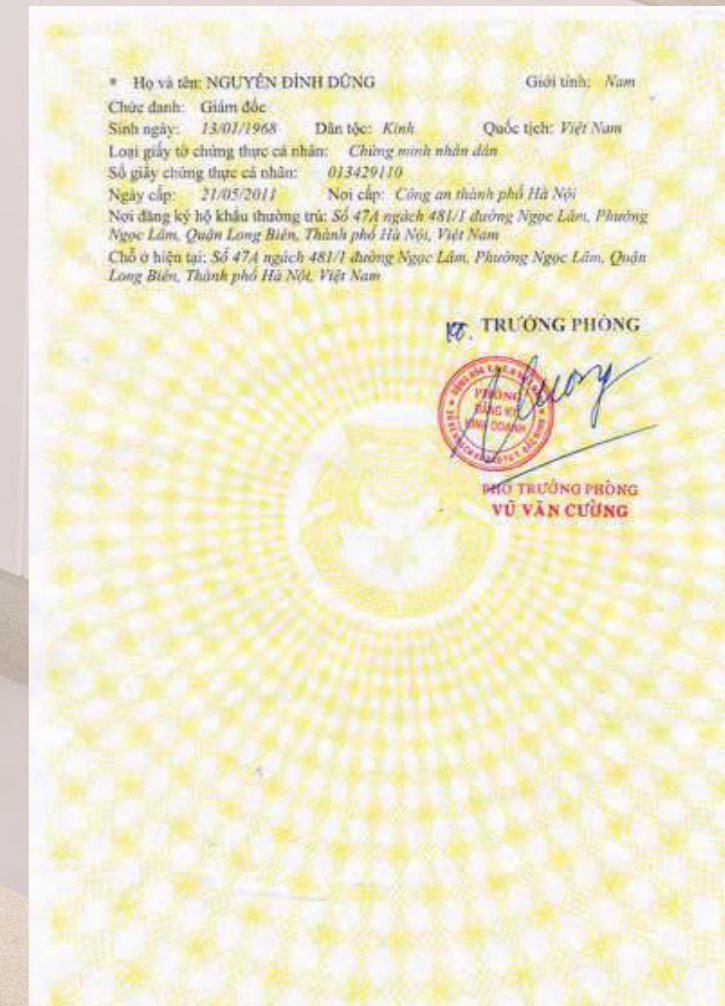
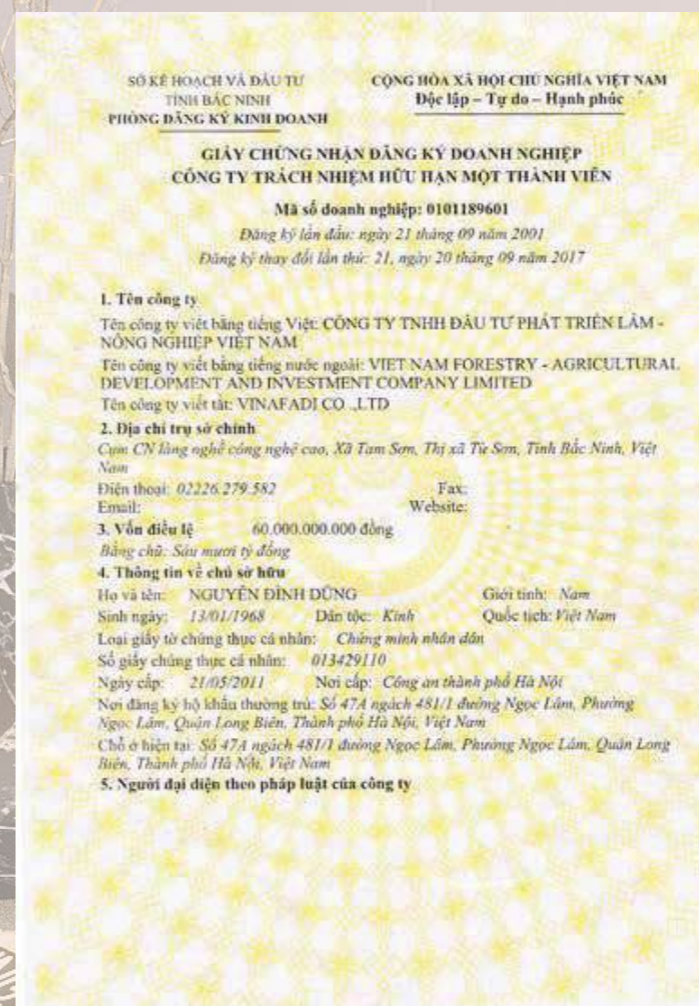



“ Located in the High-Tech Craft Village Industrial Cluster, Tam Son Ward, Bac Ninh Province, CIARA enjoys a strategic location with excellent transportation links to major cities such as Hanoi, Bac Giang, Thai Nguyen, Hai Phong, and Quang Ninh.

**2.000 m<sup>2</sup>**  
FACTORY AREA

---

**1.000 m<sup>2</sup>**  
SHOWROOM AREA

---

**50.000**  
PRODUCTS/YEAR

◆ **FACTORY SCALE**

# COMPANY HISTORY & DEVELOPMENT JOURNEY

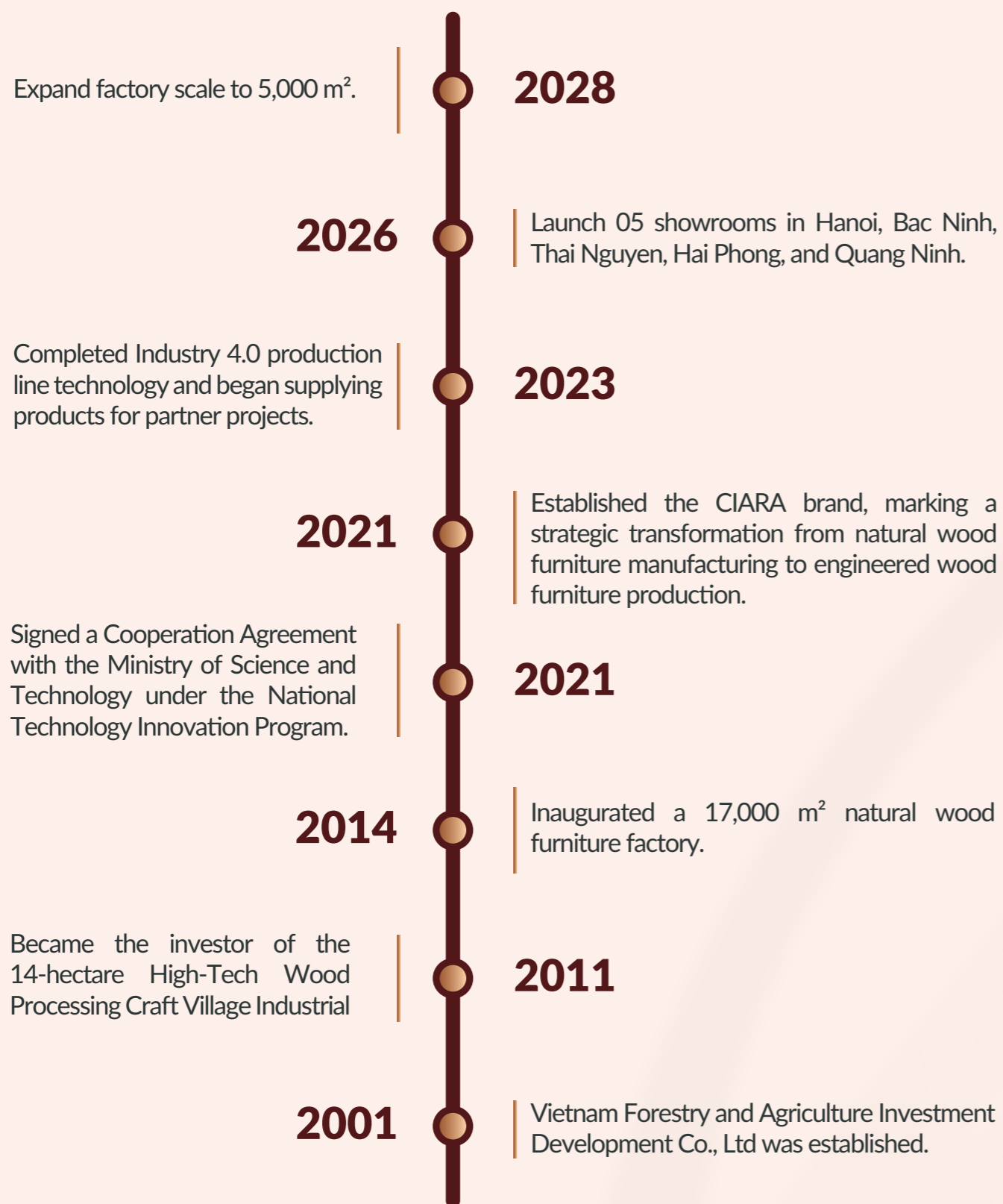

**VISION, MISSION** ◆  
**CORE VALUES**

# ORGANIZATIONAL CHART

Scale: 100- 150 Employee

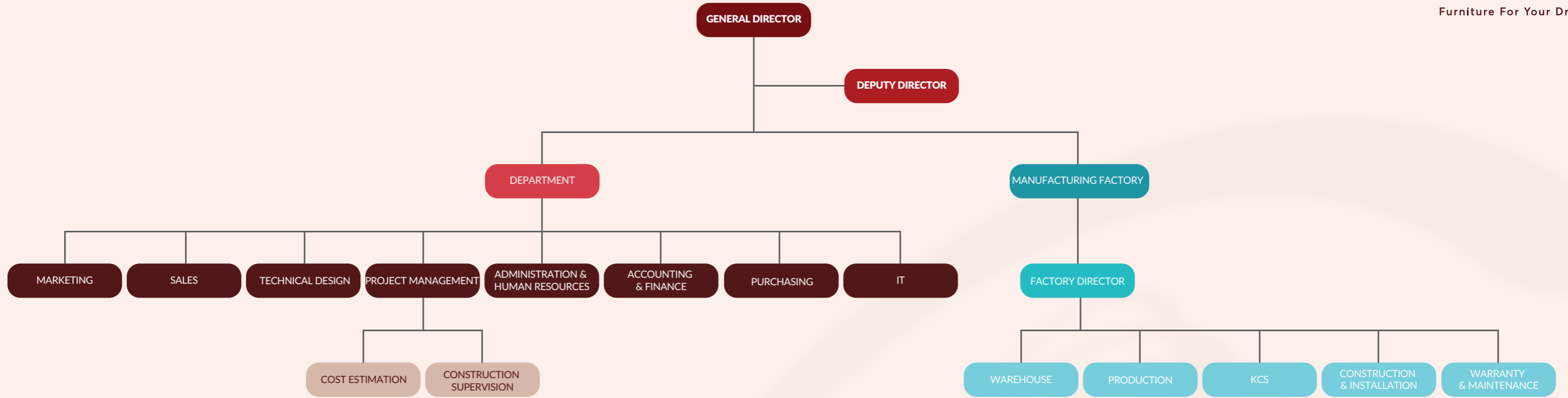

# ◆ MACHINERY & EQUIPMENT



## Storeteq

**S-200**

### SMART PANEL STORAGE SYSTEM - HOMAG

Efficient transportation and storage of panel materials. The multifunctional storage system, integrated with artificial intelligence, ensures seamless connectivity with production systems and warehouse management.

This is a critical stage in Industry 4.0 manufacturing technology.

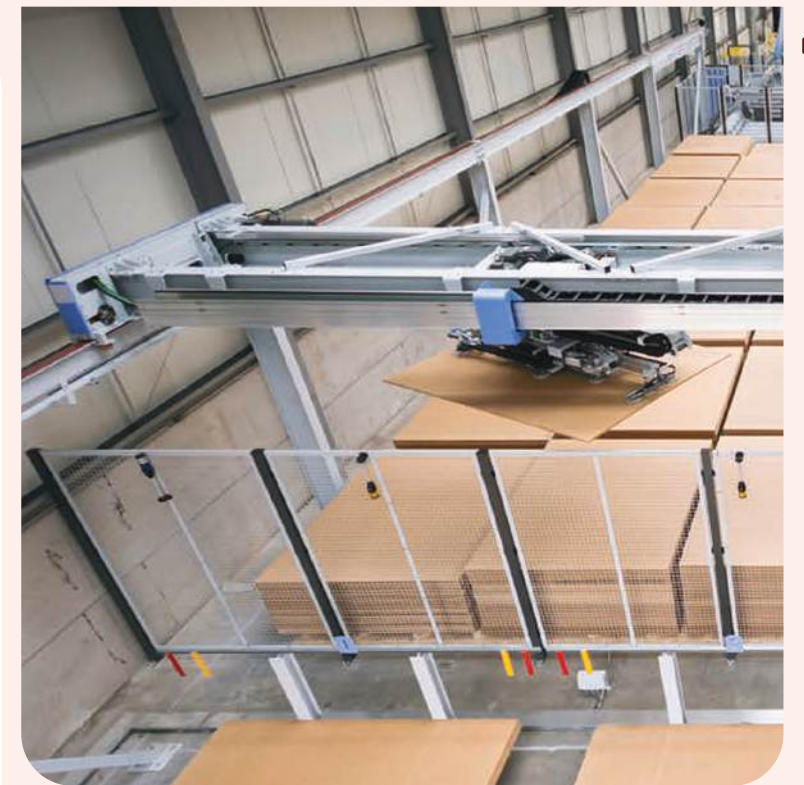

Industrial machinery



Industrial machinery



Automatic labeling and sticker application for panels at the material preparation station.



Automatically picks up workpieces from the preparation table and transfers them to the machining area.

## **Centateq N-210**

**CNC CENTRAL CUTTING MACHINE  
NESTING- HOMAG**

This CNC machine line applies the most advanced Nesting technology available today, enhancing the production workflow of furniture made from engineered wood panels. The processed products achieve an almost absolute level of precision.

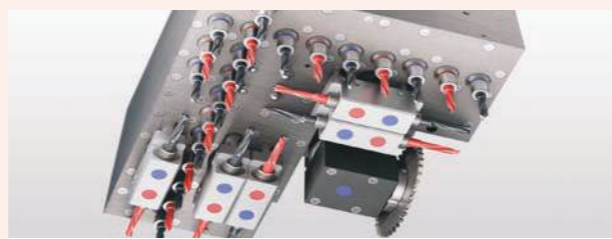

Integrates high-speed drilling technology with drill bits and cutting blades arranged both vertically and horizontally to enhance machining productivity.

## **Sawteq B-200**

**PANEL SAW - HOMAG**

This is a Panelsaw machine that allows users to automatically set wood cutting processes, capable of cutting multiple panels in a single operation, thereby improving factory productivity.

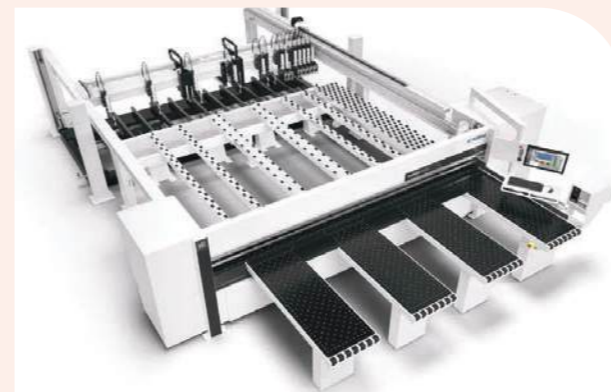

Industrial machinery



The material stop points can be positioned precisely, either automatically or manually, with ease using the pneumatic system.



Automatic loading of workpieces from the rear.



Industrial machinery

## Edgeteq S-300

EDGE BANDING MACHINE - HOMAG

Automatic edge banding machine capable of applying EVA & PUR glue.

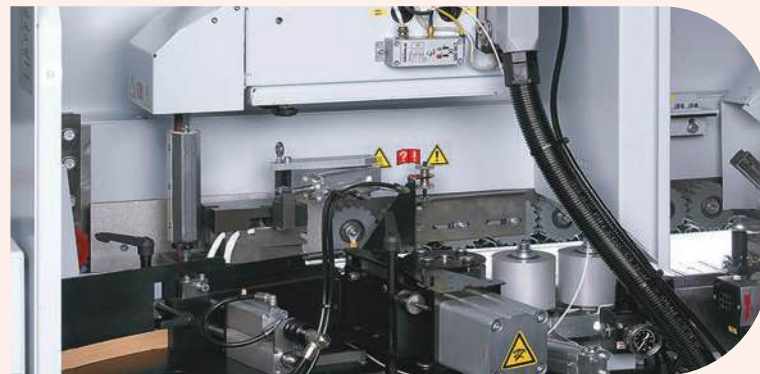

High availability and optimized glue quality thanks to the Quickmelt glue unit and pre-melting system.  
Equipped with a PUR glue pre-filter, ensuring the best bonding quality for the products.



Cutting unit with linear guidance for high precision, allowing easy adjustment between angled and straight cuts.

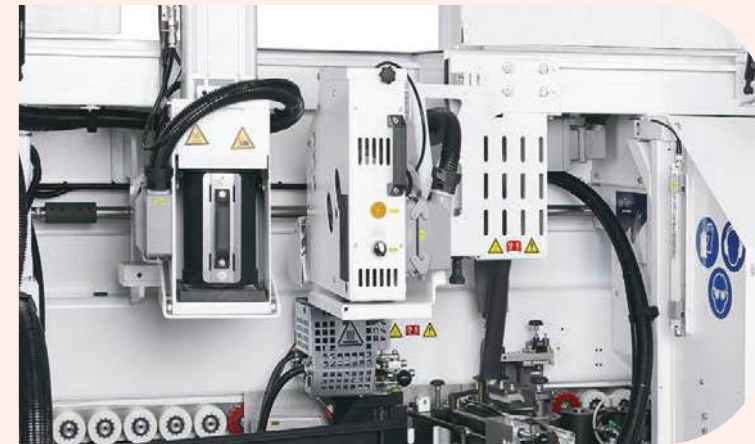

Equipped with two glue pots for EVA and PUR, enabling quick and easy glue type changes.



Milling and cutting units are powered by servo-controlled motors, specifically designed to handle high-gloss surfaces such as Acrylic.



Industrial machinery

## Edgeteq S-380

EDGE BANDING MACHINE - HOMAG

Automatic edge banding machine capable of applying both EVA & PUR adhesives.

Key features are similar to the Edgeteq S-300 edge banding machine.





Industrial machinery

## Drilteq V-200

CNC DRILLING MACHINE - HOMAG

A versatile CNC machine designed for drilling, milling, and grooving on engineered wood products.

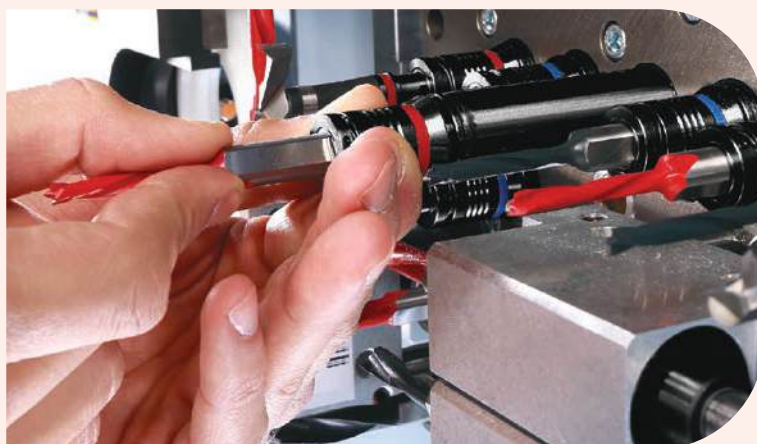

Equipped with up to 13 high-speed vertical drilling spindles, including a quick-change drill system.



Operated quickly and efficiently via an intuitive touchscreen interface and Power-Touch technology.



Industrial machinery

## Drilteq V-500

CNC DRILLING MACHINE - HOMAG

A versatile CNC machine designed for drilling, milling, and grooving large engineered wood products.

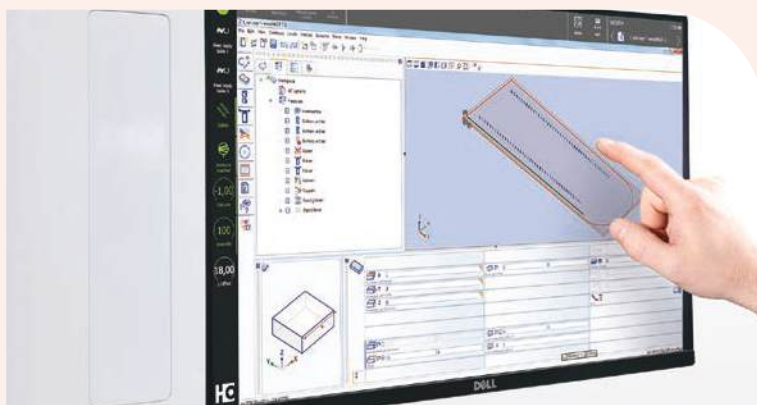

Operated quickly and efficiently via an intuitive touchscreen interface and Power-Touch technology.

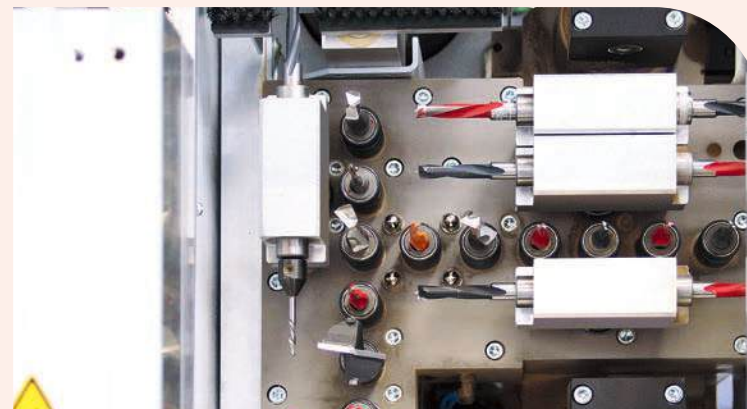

Equipped with up to 36 high-speed vertical drilling spindles, including a quick-change drill system.



Automation is enhanced through barcode integration and connection to the automatic part return system.

# AUTOMATED PRODUCTION LINE OVERVIEW CIARA SMART FACTORY

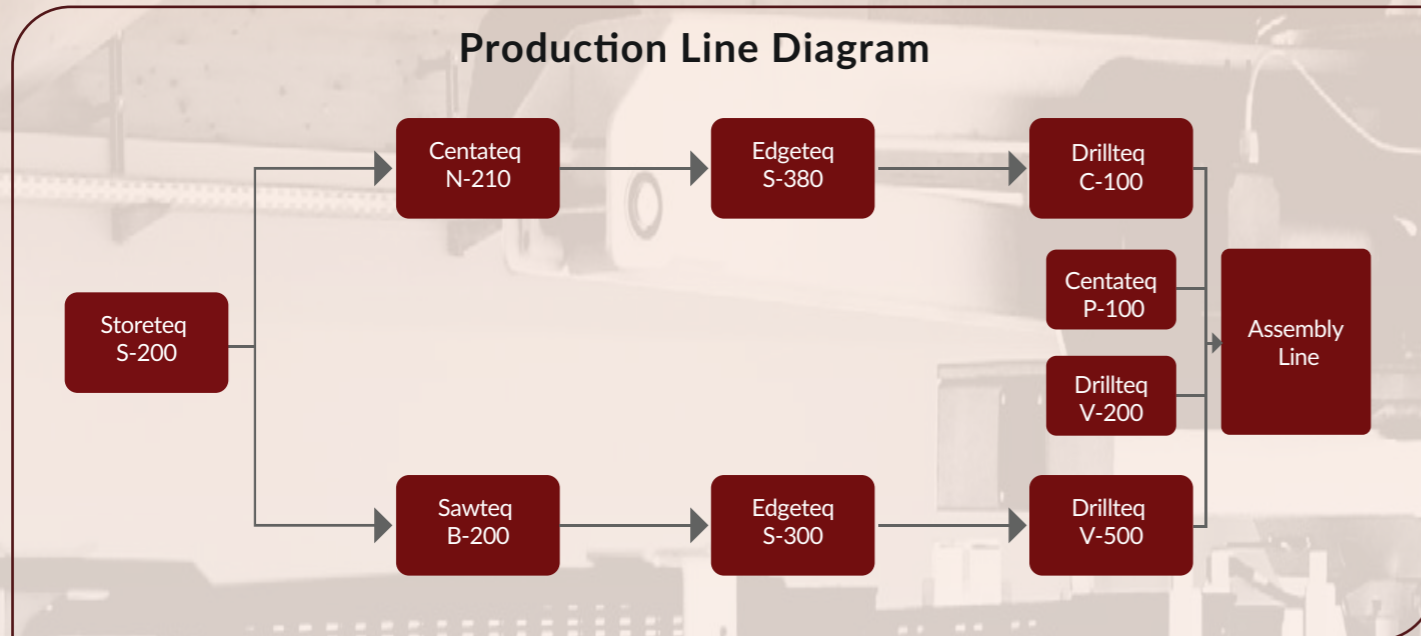

SMART BOARD STORAGE SYSTEM TO CUTTING MACHINE

CIARA has partnered with the **Ministry of Science and Technology** under the National Technology Innovation Program to **build a fully automated furniture production line using engineered wood panels, with a designed output capacity of 10,000 m<sup>3</sup> per year.**



AUTOMATIC CONVEYOR SYSTEM TO EDGE BANDING MACHINE

As the first factory in Vietnam to apply Industry 4.0 automation technology in wooden furniture manufacturing, CIARA integrates automation from raw material input to final product packaging.



AUTOMATIC CONVEYOR SYSTEM TO DRILLING MACHINE



## ◆ HIGH-QUALITY LASER EDGE BANDING

This is the most advanced and high-end edge banding technology available today, delivering a seamless, refined, and luxurious finish to wooden surfaces.

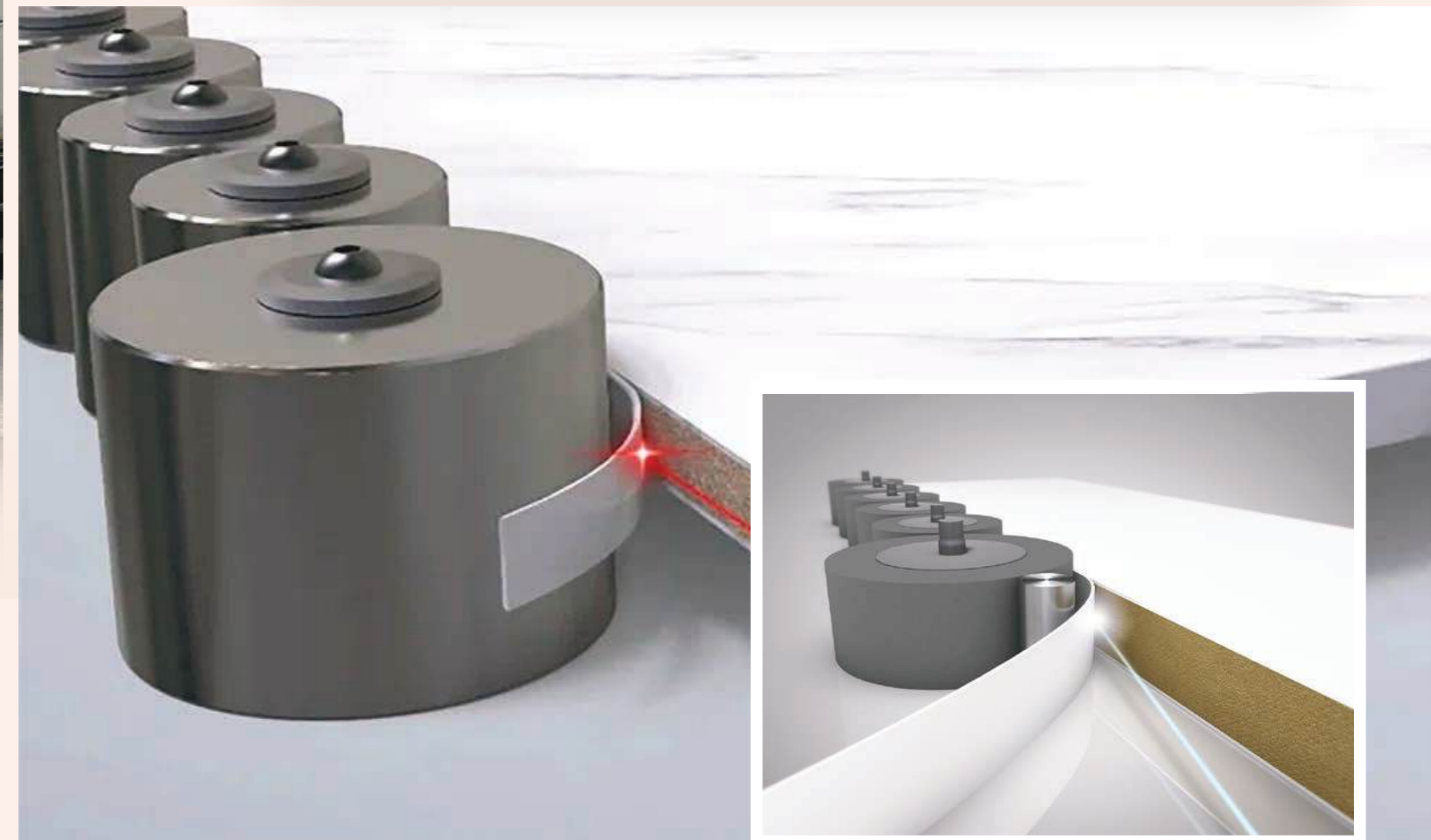

## ◆ LASER EDGE BANDING PREMIUM SEAMLESS FINISH

Unlike traditional hot-melt adhesive methods, LASER edge banding uses a laser beam to activate a special polymer layer on the edge banding tape, creating a strong, precise, and visually perfect bond with engineered wood panels (such as MFC, MDF) – without visible glue lines.

01

This process is commonly referred to as the "No Line" edge banding due to the near-invisible joint, resulting in a clean and modern appearance.

02

LASER edge banding technology is perfectly suited for the production of furniture that demands exceptional aesthetics and superior durability – especially in humid environments or areas with frequent temperature fluctuations.

It's the optimal solution for premium interiors where visual perfection, seamless joints, and long-term performance are required.

Real Products Utilizing LASER Edge Banding at CIARA:

- High-end kitchen cabinets
- Wardrobes
- Desks and decorative shelving
- Office and hotel furniture



# PRODUCTS

## RECEPTION ROOM



**Stone-top Coffee Table:** Luxuriously designed coffee table featuring a natural ceramic stone top that is scratch-resistant and waterproof, supported by premium stainless steel legs.



**Armchair (or Single Sofa):** Upholstered with premium simili leather and supported by gold-plated stainless steel legs – delivering a luxurious and comfortable feel.



**Interior Door (or Swing Door):** Made from moisture-resistant MDF wood, combined with luxurious gold PVD-plated stainless steel trim.



**Wall Art (or Wall Panel Art):** The artwork features exquisite patterns, creating a luxurious effect and depth, delivering a classy.



# PRODUCTS

## CEO'S OFFICE



**Director's Desk:** A modern desk made from premium Melamine-coated MDF wood, highlighted by luxurious PVD-plated metal trim, showcasing executive prestige.



**Director's Chair:** A high-end leather swivel chair with an ergonomic design, featuring natural wood armrest covers and chrome-plated alloy legs, offering comfort and professionalism.



**Decorative Cabinet (or Display Cabinet):** A sophisticated built-in design made from Laminate-coated MDF wood, combined with recessed LED lighting to create a luxurious, modern focal point for the workspace.



**Console cabinet:** Made from moisture-proof MDF covered with Laminate, combined with luxurious and sophisticated PVD-plated stainless steel legs and edges.



**Meeting Table and Chair Set:** Features sophisticated dark wood tones combined with light cream fabric chairs. The meeting table is equipped with power outlets, suitable for high-end internal meeting and workspace.



**Wood Wall Panel:** Harmonious design using premium Laminate-coated moisture-resistant MDF wood, combined with glass and modern LED lighting.

# ◆ PRODUCTS BOARDROOM



**Meeting Table:** Made of premium Inchem-painted moisture-resistant MDF wood, featuring a thick tabletop with a smooth, glossy finish, conveying a sturdy and luxurious appearance.



**Meeting Chair:** Upholstered in premium leather or imported linen fabric, featuring a powder-coated alloy frame and anti-scratch, soft, and durable PU castors.



**Wall Panel:** Premium wood paneling for the meeting room, featuring elegant light tones that highlight the CIARA brand logo in burgundy red.



**Door:** Harmonious design with a frame of premium Inchem-painted engineered wood, featuring a wood-grain surface that conveys an elegant and professional feel.



# PRODUCTS WORKSPACE



**Work Desk (or Office Desk):** Made from Melamine-coated moisture-resistant MDF wood, combined with a sophisticated desk modesty panel – durable, scratch-resistant, and neat.



**Manager's Chair:** Modern design featuring a chrome-plated steel frame, backrest upholstered in premium simili leather, and a 360° swivel base with flexible height adjustment.



**Manager's Filing Cabinet:** Made from Melamine-coated moisture-resistant MDF, combined with elegant white Inchem-painted doors, achieving a sophisticated.



**Staff Chair (or Employee Chair):** A high-end leather swivel chair featuring softly padded armrests, 360° swivel capability, flexible height adjustment, and convenient castors, ensuring



**Coffee Table:** A sophisticated design featuring luxurious PVD-plated stainless steel legs and a durable ceramic stone tabletop, delivering a modern and classy look.



**Sofa:** Features a sturdy frame, upholstered with premium simili leather, combined with comfortable foam cushioning and matching throw pillows, providing a luxurious and comfortable feel.

# PRODUCTS

## LIVING ROOM



**Wood Wall Panel:** Paneled with luxurious Veneer-coated MDF, creating a warm and sophisticated focal point for the space.



**TV Stand (or Entertainment Console):** Modern design featuring harmonious brown and gray tones, optimizing storage and highlighting the entertainment area.



**Tea table:** Smart box design featuring convenient drawers and a luxurious wooden top.



**Sofa:** High-class sofa in cream and brown color, soft and modern, bringing a feeling of absolute relaxation.



# PRODUCTS

## KITCHEN AND DINING AREA



**Kitchen Cabinets:** Premium cabinet design, with upper cabinets made from moisture-resistant MDF coated with high-gloss Acrylic. The subtle color coordination brings a bright and airy feel to the kitchen space.



**Kitchen Island:** Modern design featuring a moisture-resistant MDF wood frame, finished with imported Inchem paint, custom-matched to the rendering's color scheme.



**Wine Cabinet (or Display Cabinet):** Moisture-resistant MDF cabinet in a beige tone, featuring integrated LED lighting, enhancing the beauty and value of the



**Dining Set (or Dining Table and Chair Set):** A dining set designed with sophistication, balancing aesthetic appeal and practical function. The dining table features a luxurious, easy-to-clean stone top.

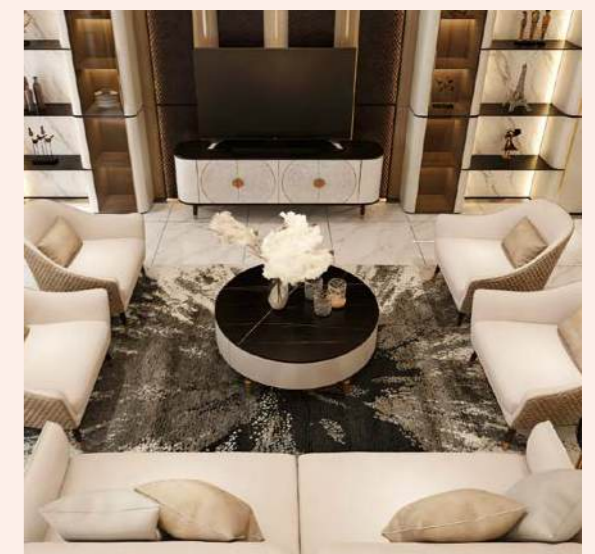

# PRODUCTS BEDROOM



**Bedding:** Features a sturdy natural wood frame, upholstered in high-grade simili leather or premium fabric, with comfortable foam cushioning and harmonious matching throw pillows for the resting space.



**TV Stand:** An MDF cabinet featuring a minimalist design and a refined finished surface, ensuring both functionality and aesthetic appeal.



**Bedside Cabinet (or Nightstand/Bedside Table):** A compact, modern cabinet, harmonizing with the overall style of the bedroom space.

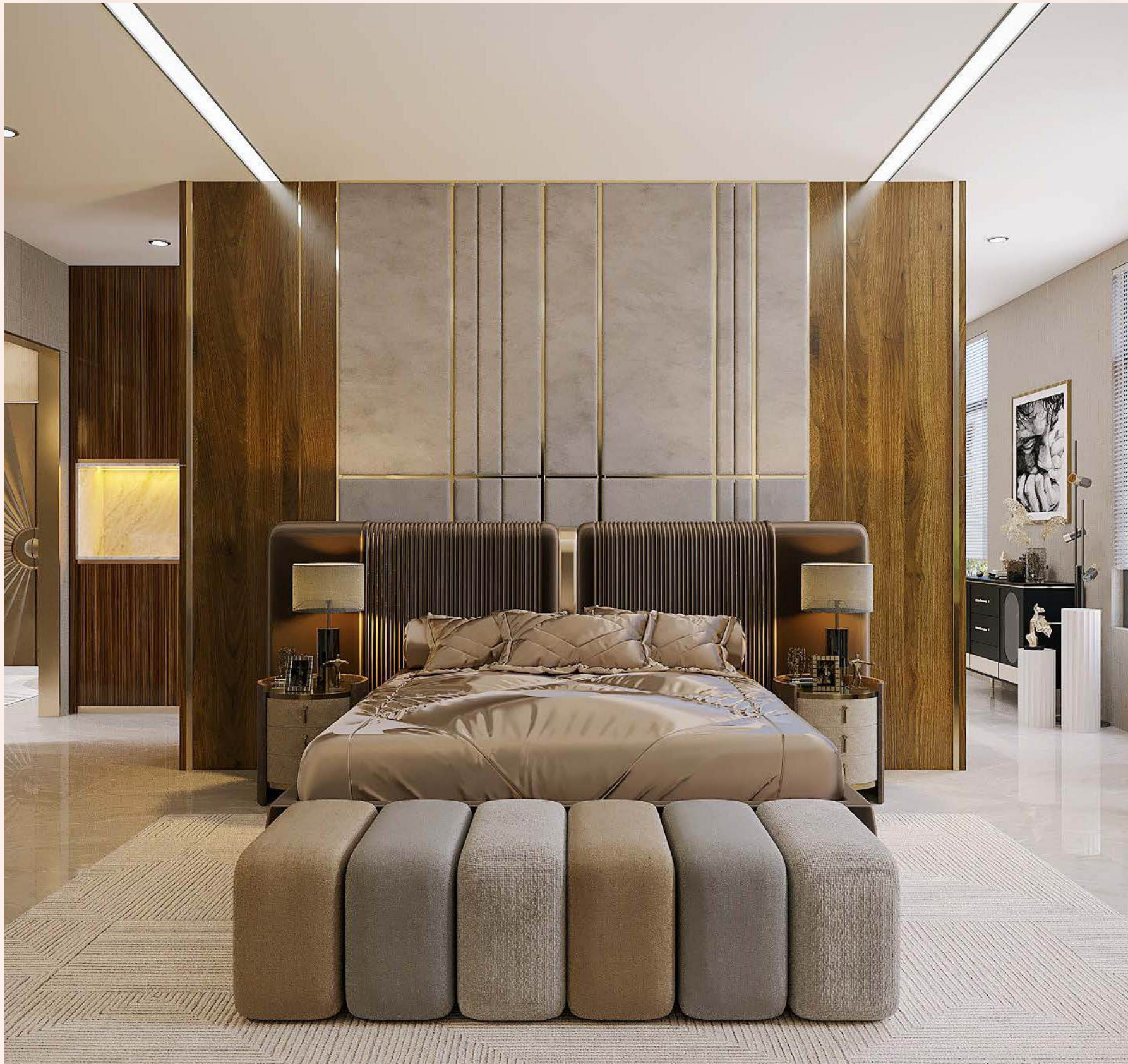

**Console Table:** Harmonious, compact design with a luxurious finished surface, bringing balance to the space.



**Sofa:** Compact and sophisticated design, easy to arrange within the bedroom space, creating a luxurious and harmonious accent for the overall interior.

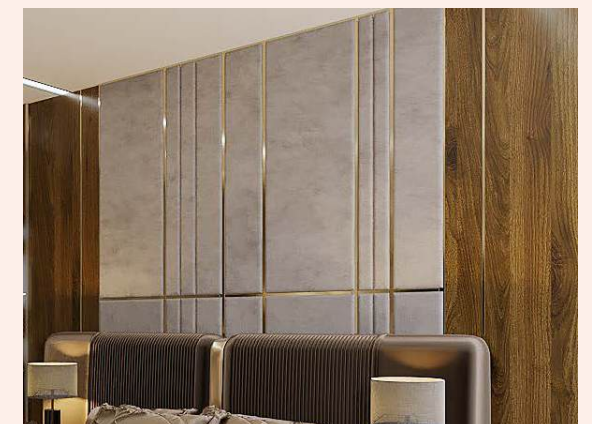

**Headboard Wall Panel:** A luxurious design combining high-grade wood and symmetrical upholstered leather sections, creating a sophisticated and warm accent for the bedroom space.

# PRODUCTS

## DRESSING ROOM



**Wardrobe (or Closet):** Harmonious design featuring luxurious smoky gray glass doors, an MDF cabinet body, and beige-white painted doors, creating a sophisticated and modern storage space.



**Jewelry Cabinet (or Jewelry Armoire):** Compact design, crafted from modern gray Acrylic material. It optimizes storage for personal accessories and jewelry.



**Dressing Table (or Vanity Table):** A sleek design produced from premium Melamine-coated moisture-resistant MDF wood, ensuring superior durability and moisture resistance.



**Mirror:** Premium mirror providing true-to-life, clear reflections, with an exquisitely crafted frame ensuring durability and safety during use.



# 01

**G-GROUP TECHNOLOGY GROUP PROJECT**

## LUXURY WORKSPACE

Located in the heart of Hanoi, G-Group Office Complex is a symbol of modern architecture and smart space solutions. With a scale of 18 floors, the project demonstrates CIARA's outstanding capacity in the field of manufacturing and constructing high-end interiors.



## ◆ HIGHLIGHTED PROJECTS

**Project:**  
G-Group Office Complex

**Scale:** 18 Floors

**Location:** Hanoi City

**Investor:**  
QUANG CHUNG TOURISM SERVICES AND  
REAL ESTATES TRADING JOINT STOCK  
COMPANY

**Interior construction unit:** CIARA

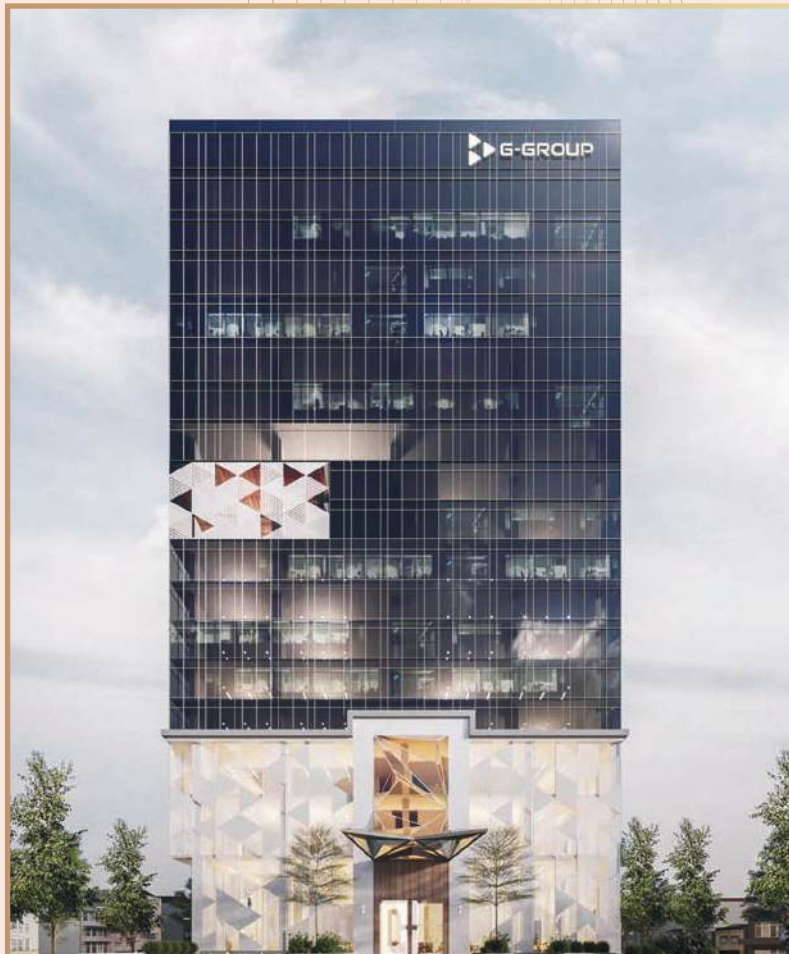

## 02 GOOD WAY FACTORY PROJECT

### MODERN PRODUCTION SPACE

CIARA has completed the interior construction for Good Way Factory - a 6,000 m<sup>2</sup> high-tech project in Thai Binh. The project is implemented according to modern factory standards, combining optimal working space and advanced product display area.



**Project:**  
Good Way Vietnam Factory

**Scale:** 6000m<sup>2</sup>

**Location:** Thai Binh city

**Investor:**  
GOOD WAY TECHNOLOGY VIETNAM  
COMPANY LIMITED

**Interior construction unit:** CIARA



# 03 DANANG MUSEUM PROJECT

## HERITAGE EXHIBITION SPACE

CIARA is honored to construct the interior of Da Nang Museum - a key cultural project of the city, where the historical and artistic values of the Central region are preserved and honored. With an area of over 8,600 m<sup>2</sup>, the project offers a modern, sophisticated and ethnically rich exhibition space.



**Project:**  
Danang Museum

**Scale:** 8686 m<sup>2</sup>

**Location:** Bach Dang Ward, Da Nang City

**Investor:** Da Nang People's Committee

**Interior construction unit:** CIARA



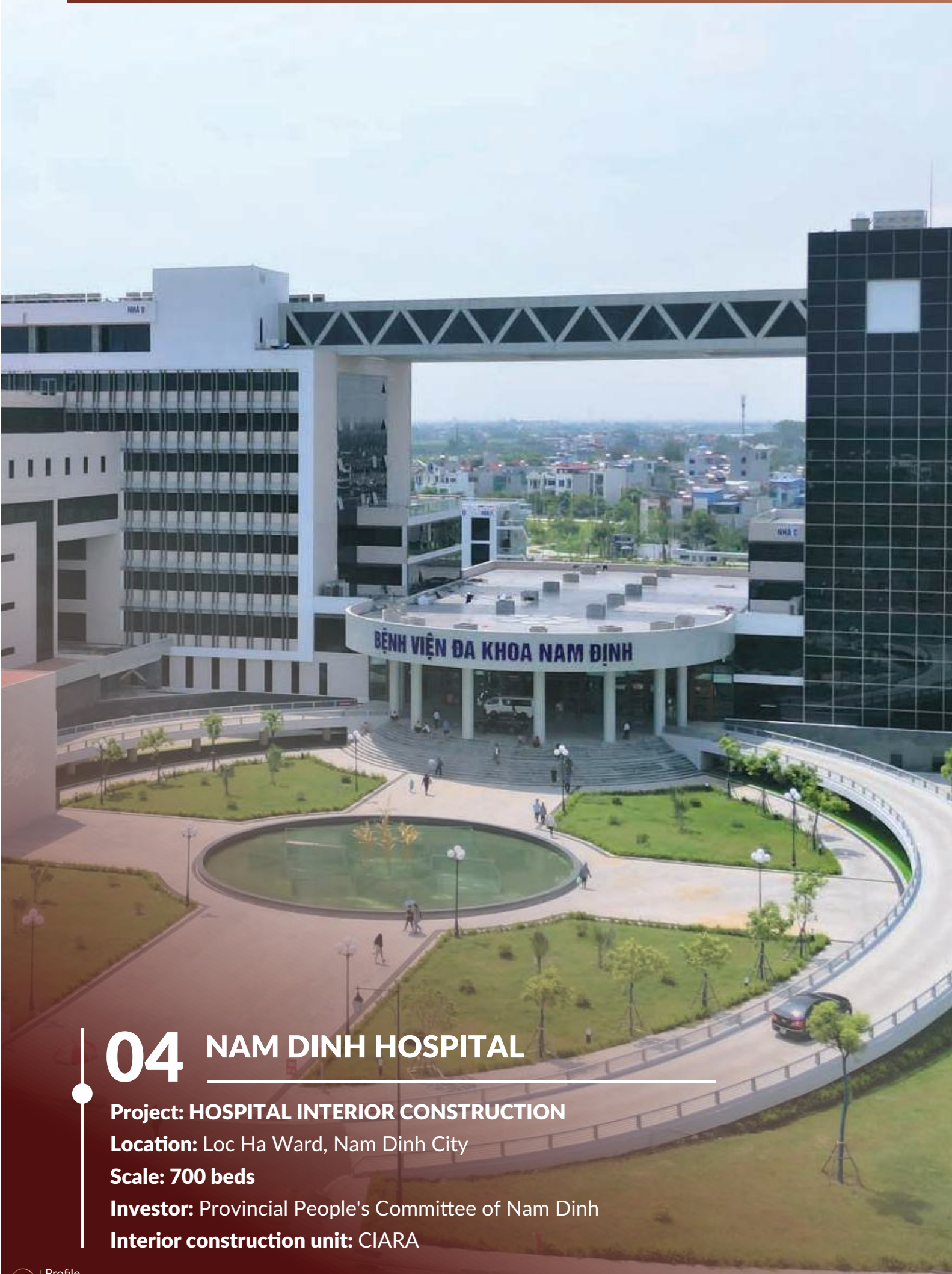

# 04 NAM DINH HOSPITAL

**Project:** HOSPITAL INTERIOR CONSTRUCTION

**Location:** Loc Ha Ward, Nam Dinh City

**Scale:** 700 beds

**Investor:** Provincial People's Committee of Nam Dinh

**Interior construction unit:** CIARA

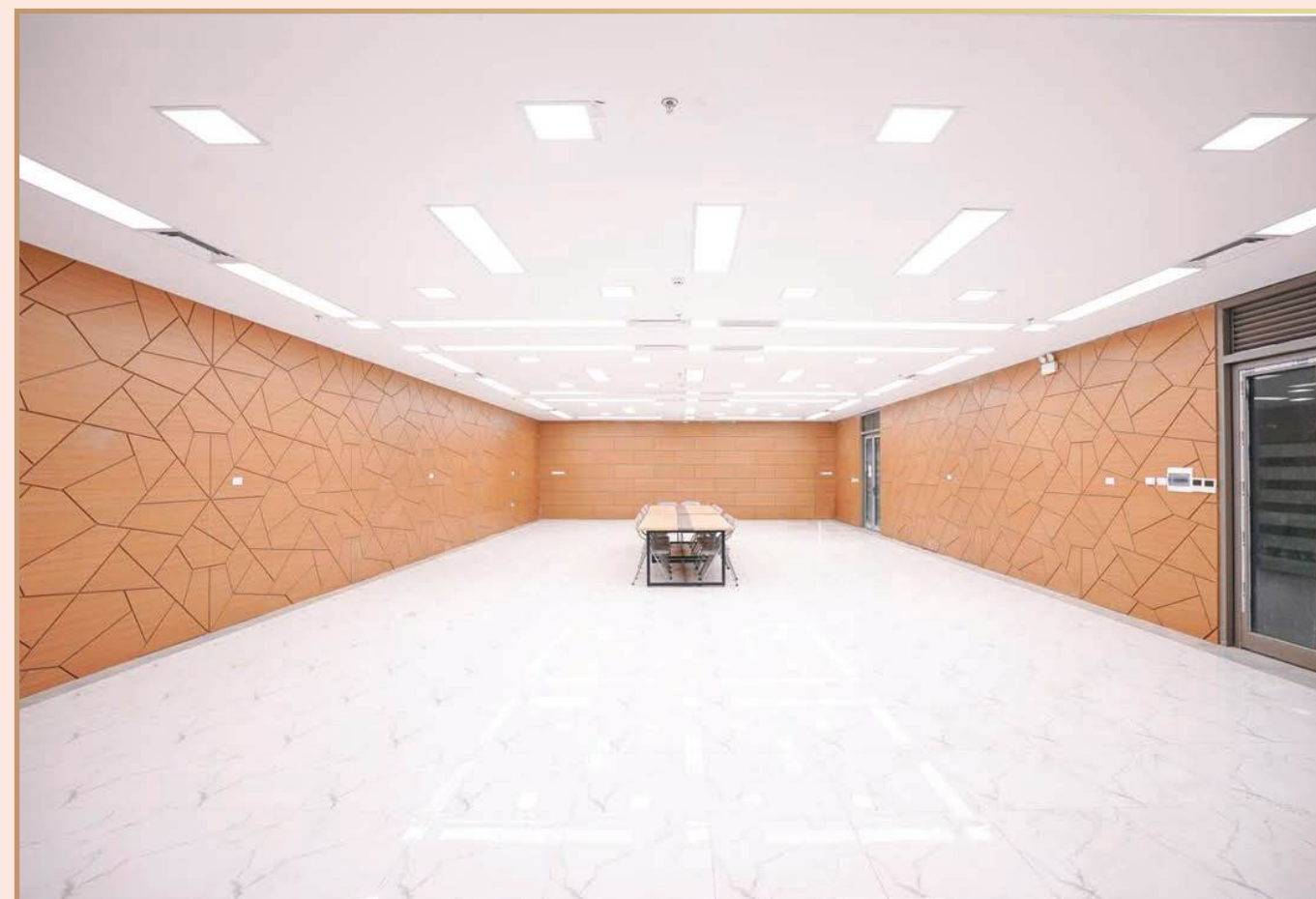



# 05 THE NINETY COMPLEX COMMERCIAL COMPLEX

**Project:** COMMERCIAL SERVICE COMPLEX, OFFICE FOR RENT AND HOTEL APARTMENTS  
**Location:** No. 90 Lang Road, Nga Tu So Ward, Dong Da District, Hanoi  
**Scale:** 27 floors  
**Investor:** Anh Sao Trading Company Limited  
**Interior construction unit:** CIARA

ĐƯỜNG



# 06 HUNG VUONG OFFICE BUILDING

**Project:** OFFICE INTERIOR CONSTRUCTION

**Location:** Lot CN8.2, Nam Cau Kien Industrial Park, Hai Phong City, Vietnam

**Scale:** 1.050m<sup>2</sup>

**Investor:** HUNG VUONG LOGISTICS JOINT STOCK COMPANY

**Interior construction unit:** CIARA



# 07 HANOI UNIVERSITY OF SCIENCE AND TECHNOLOGY

**Project:** TRAINING ROOM INTERIOR CONSTRUCTION

**Location:** Dai Co Viet Street, University of Science and Technology, Hai Ba Trung District, Hanoi.

**Interior construction unit:** CIARA





# 08 CONSHUB

**Project:** CONSTRUCTION INDUSTRY CONNECTION CENTER  
**Location:** National Convention Center, Gate 01 Thang Long Avenue / Gate 02 Pham Hung Street, Nam Tu Liem District, Hanoi  
**Investor:** Consmedia Construction Media Joint Stock Company  
**Interior construction unit:** CIARA





# 09 LUXURY VILLA

Project: VILLA INTERIOR CONSTRUCTION

Location: Hanoi city

Scale: 4 floors

Interior construction unit: CIARA





# 10 LUXURY VILLA

Project: LINH DAM VILLA INTERIOR CONSTRUCTION

Location: Hanoi city

Scale: 4 floor

Interior construction unit: CIARA

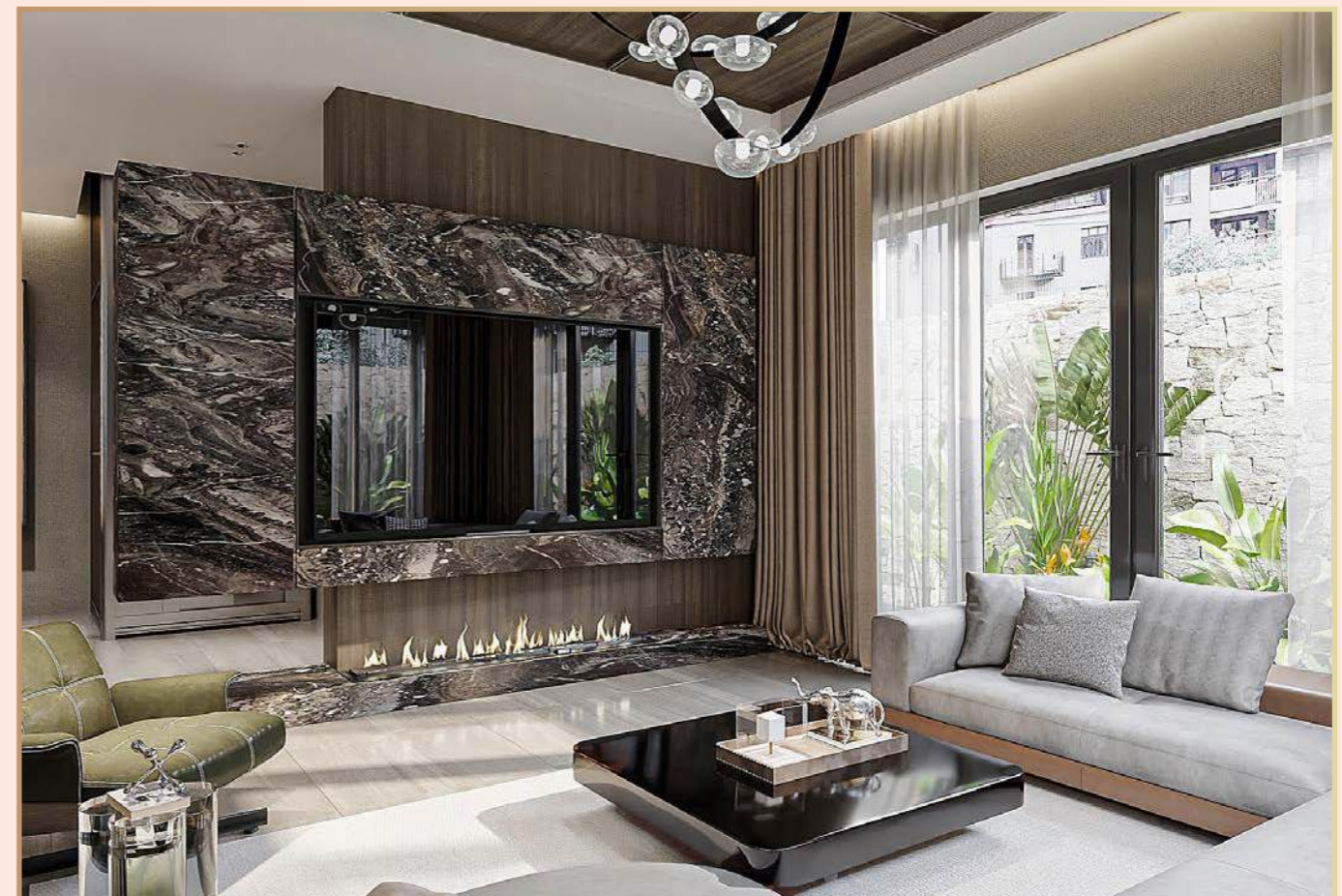



# ◆ WHY CHOOSE US?



We believe every space carries a unique mission and every project – whether a residential development, commercial complex, or luxury space – deserves to be crafted with refinement, quality, and genuine dedication.

CIARA is more than just a furniture supplier – we are a strategic partner on the journey to elevate the value of every project. We harmonize aesthetics, functionality, and emotional connection to create truly elevated living and working environments.



**A trusted partner that transforms the investor's vision into real-world projects, delivering sustainable benefits and value beyond**

### **Cost Optimization – Maximum Sustainable Value**

At CIARA, we don't just manufacture furniture — we deliver smart solutions that help investors optimize costs effectively. Through integrated design and execution, CIARA minimizes material waste, reduces unforeseen expenses, and ensures project timelines are strictly met as committed.

### **Robust Execution Capability – Ready for Projects of All Scales**

CIARA brings together a team of highly experienced architects, engineers, and project managers, fully capable of delivering large-scale and complex projects with systematic processes and strict timeline control. Quality and commitment are always our top priorities in every project we undertake.

### **Quality Standards – Elevating Project Reputation**

Every product from CIARA is the result of a strict quality control process and adherence to the highest technical standards. Consistency, durability, and refined finishing are the core elements that enhance both the value of the project and the prestige of the investor.

### **One Complete Solution – One Partner, Total Trust**

From Consultation → Design → Production → Installation → Warranty, CIARA accompanies clients throughout the entire journey. No intermediaries, no complications, just streamlined coordination, time-saving management, and optimized investment efficiency.

# THANKS FOR WATCHING!



## CIARA 4.0 FURNITURE MANUFACTURING FACTORY

📍 **Factory:** High-tech Craft Village Industrial Cluster, Tam Son Ward, Bac Ninh Province.

☎ **Tel:** 094.191.3568

✉ **Email:** [quanly@ciara.com.vn](mailto:quanly@ciara.com.vn)

🌐 **Website:** [noithatciara.com](http://noithatciara.com)